

ZEXEL Ass'y No.	104741-6352
Bosch Ass'y No.	9 460 610 360
Bosch Typecode	
Engine Type	4JB1-TC
Manufacturer	ISUZU
Edition date	14.10.03 (1)

1 Adjustment conditions

CAT	Designation	Unit	Set value	min.	max.	Actual values	OT
	Test oil		ISO4113orSAEJ967 d				
			1404 Test oil				
P	Test oil temperature	degC	45	45	50		
	Nozzle		105780-0060				
	Bosch type code		NP-DN0SD1510				
	Nozzle holder		105780-2150				
P	Opening pressure	MPa	13	13	13.3		
P	Opening pressure	kgf/cm2	133	133	136		
	Injection pipe		157805-7320				
P	Injection pipe	mm	2-6-450				
			Inside diameter - outside diameter - length (mm)				
	Joint assembly		157641-4720				
	Tube assembly		157641-4020				
P	Transfer pump pressure	kPa	20	20	20		
P	Transfer pump pressure	kgf/cm2	0.2	0.2	0.2		
	Direction of rotation (viewed from drive side)		R				
			Right				

2 Adjustment specification**2.1 Full load delivery**

CAT	Designation	Unit	Set value	min.	max.	Actual values	OT
P	Pump speed	r/min	1250	1250	1250		
P	Boost pressure	kPa	80	78.7	81.3		
P	Boost pressure	mmHg	600	590	610		
S	Average injection quantity	mm3/st.	68.6	68.1	69.1		
S	Difference in delivery	mm3/st.	3.5		3.5		
P	Basic		*				
	Remarks						
			Full				

CAT	Designation	Unit	Set value	min.	max.	Actual values	OT
P	Pump speed	r/min	800	800	800		
P	Boost pressure	kPa	40.65	39.3	42		
P	Boost pressure	mmHg	305	295	315		
S	Average injection quantity	mm3/st.	48.2	47.7	48.7		
S	Difference in delivery	mm3/st.	4.5		4.5		
P	Basic		*				
	Remarks						
			CBS				

CAT	Designation	Unit	Set value	min.	max.	Actual values	OT
P	Pump speed	r/min	2300	2300	2300		
P	Boost pressure	kPa	80	78.7	81.3		
P	Boost pressure	mmHg	600	590	610		
C	Average injection quantity	mm3/st.	19.6	16.1	23.1		

CAT	Designation	Unit	Set value	min.	max.	Actual values	OT
P	Pump speed	r/min	1900	1900	1900		
P	Boost pressure	kPa	80	78.7	81.3		
P	Boost pressure	mmHg	600	590	610		
C	Average injection quantity	mm3/st.	71	66.5	75.5		

CAT	Designation	Unit	Set value	min.	max.	Actual values	OT
P	Pump speed	r/min	1250	1250	1250		
P	Boost pressure	kPa	0	0	0		
P	Boost pressure	mmHg	0	0	0		
C	Average injection quantity	mm3/st.	51.1	47.6	54.6		

CAT	Designation	Unit	Set value	min.	max.	Actual values	OT
P	Pump speed	r/min	1250	1250	1250		

P	Boost pressure	kPa	80	78.7	81.3		
P	Boost pressure	mmHg	600	590	610		
C	Average injection quantity	mm ³ /st.	68.6	67.6	69.6		
CAT	Designation	Unit	Set value	min.	max.	Actual values	OT
P	Pump speed	r/min	800	800	800		
P	Boost pressure	kPa	40.65	39.3	42		
P	Boost pressure	mmHg	305	295	315		
C	Average injection quantity	mm ³ /st.	48.2	47.2	49.2		
CAT	Designation	Unit	Set value	min.	max.	Actual values	OT
P	Pump speed	r/min	600	600	600		
P	Boost pressure	kPa	18.65	17.3	20		
P	Boost pressure	mmHg	140	130	150		
C	Average injection quantity	mm ³ /st.	37.7	34.7	40.7		
CAT	Designation	Unit	Set value	min.	max.	Actual values	OT
P	Pump speed	r/min	400	400	400		
P	Boost pressure	kPa	0	0	0		
P	Boost pressure	mmHg	0	0	0		
C	Average injection quantity	mm ³ /st.	42	36.5	47.5		

2.2 Governing

CAT	Designation	Unit	Set value	min.	max.	Actual values	OT
P	Pump speed	r/min	2300	2300	2300		
P	Boost pressure	kPa	80	78.7	81.3		
P	Boost pressure	mmHg	600	590	610		
S	Average injection quantity	mm ³ /st.	19.6	16.6	22.6		
S	Difference in delivery	mm ³ /st.	4.5		4.5		
P	Basic		*				
CAT	Designation	Unit	Set value	min.	max.	Actual values	OT
P	Pump speed	r/min	2400	2400	2400		
P	Boost pressure	kPa	80	78.7	81.3		
P	Boost pressure	mmHg	600	590	610		
C	Average injection quantity	mm ³ /st.	12		12		

2.3 Idle

CAT	Designation	Unit	Set value	min.	max.	Actual values	OT
P	Pump speed	r/min	385	385	385		
P	Boost pressure	kPa	0	0	0		
P	Boost pressure	mmHg	0	0	0		
S	Average injection quantity	mm ³ /st.	8.1	6.1	10.1		
S	Difference in delivery	mm ³ /st.	2		2		
P	Basic		*				
CAT	Designation	Unit	Set value	min.	max.	Actual values	OT
P	Pump speed	r/min	385	385	385		
P	Boost pressure	kPa	0	0	0		
P	Boost pressure	mmHg	0	0	0		
C	Average injection quantity	mm ³ /st.	8.1	6.1	10.1		
CAT	Designation	Unit	Set value	min.	max.	Actual values	OT
P	Pump speed	r/min	500	500	500		
P	Boost pressure	kPa	0	0	0		
P	Boost pressure	mmHg	0	0	0		
C	Average injection quantity	mm ³ /st.	3		3		

2.4 Start

CAT	Designation	Unit	Set value	min.	max.	Actual values	OT
P	Pump speed	r/min	100	100	100		
P	Boost pressure	kPa	0	0	0		
P	Boost pressure	mmHg	0	0	0		
S	Average injection quantity	mm ³ /st.	85	80	90		
P	Basic		*				

2.5 Stop

CAT	Designation	Unit	Set value	min.	max.	Actual values	OT
P	Pump speed	r/min	385	385	385		
P	Boost pressure	kPa	0	0	0		
P	Boost pressure	mmHg	0	0	0		
C	Average injection quantity	mm ³ /st.	0	0	0		
	Remarks						
		Magnet OFF					

2.6 Overflow

CAT	Designation	Unit	Set value	min.	max.	Actual values	OT
P	Pump speed	r/min	1500	1500	1500		
P	Boost pressure	kPa	80	78.7	81.3		
P	Boost pressure	mmHg	600	590	610		
C	Overflow quantity with S/T ON	cm3/min	471	342	600		
C	Overflow quantity with S/T OFF	cm3/min	519	390	648		

2.7 Pump chamber pressure

CAT	Designation	Unit	Set value	min.	max.	Actual values	OT
P	Pump speed	r/min	1500	1500	1500		
P	Boost pressure	kPa	80	78.7	81.3		
P	Boost pressure	mmHg	600	590	610		
S	Pressure	kPa	480.5	461	500		
S	Pressure	kgf/cm2	4.9	4.7	5.1		
P	Basic		*				

CAT	Designation	Unit	Set value	min.	max.	Actual values	OT
P	Pump speed	r/min	1500	1500	1500		
P	Boost pressure	kPa	80	78.7	81.3		
P	Boost pressure	mmHg	600	590	610		
C	Pressure with S/T OFF	kPa	480.5	461	500		
C	Pressure with S/T OFF	kgf/cm2	4.9	4.7	5.1		

CAT	Designation	Unit	Set value	min.	max.	Actual values	OT
P	Pump speed	r/min	1900	1900	1900		
P	Boost pressure	kPa	80	78.7	81.3		
P	Boost pressure	mmHg	600	590	610		
C	Pressure with S/T OFF	kPa	598.5	569	628		
C	Pressure with S/T OFF	kgf/cm2	6.1	5.8	6.4		

2.8 Timer

CAT	Designation	Unit	Set value	min.	max.	Actual values	OT
P	Pump speed	r/min	1500	1500	1500		
P	Boost pressure	kPa	80	78.7	81.3		
P	Boost pressure	mmHg	600	590	610		
S	Timer stroke	mm	5.1	4.9	5.3		
P	Basic		*				

CAT	Designation	Unit	Set value	min.	max.	Actual values	OT
P	Pump speed	r/min	750	750	750		
P	Boost pressure	kPa	80	78.7	81.3		
P	Boost pressure	mmHg	600	590	610		
C	Timer stroke with S/T ON	mm	1	1			

CAT	Designation	Unit	Set value	min.	max.	Actual values	OT
P	Pump speed	r/min	1500	1500	1500		
P	Boost pressure	kPa	80	78.7	81.3		
P	Boost pressure	mmHg	600	590	610		
C	Timer stroke with S/T OFF	mm	5.1	4.9	5.3		

CAT	Designation	Unit	Set value	min.	max.	Actual values	OT
P	Pump speed	r/min	1700	1700	1700		
P	Boost pressure	kPa	80	78.7	81.3		
P	Boost pressure	mmHg	600	590	610		
C	Timer stroke with S/T OFF	mm	7.1	6.7	7.5		

CAT	Designation	Unit	Set value	min.	max.	Actual values	OT
P	Pump speed	r/min	1900	1900	1900		
P	Boost pressure	kPa	80	78.7	81.3		
P	Boost pressure	mmHg	600	590	610		
C	Timer stroke with S/T OFF	mm	8.65	8.3	9		

2.9 Magnet

CAT	Designation	Unit	Set value	min.	max.	Actual values	OT
C	Max. applied voltage	V	8	8	8		
P	Test voltage	V	13	12	14		

2.10 Additional device adjustment

2.10.1 Additional device 1

Name	POTENTIOMETER ADJUSTMENT
------	--------------------------

N1=750r/min
 N2=385r/min
 V1=2.49+-0.03V
 V2=0.96+-0.4V
 V3=-V
 Q1=8.7+-1cm³/1,000st
 Q2=8.1+-2cm³/1,000st Idle
 Q3=-cm³/1,000st
 P1=80.0kPa
 P2=600mmHg

Vi			
N	V	Q	
N1	V1	Q1 P : P1 (P2)	A
N2	V2	Q2	B
	V3	Q3	B

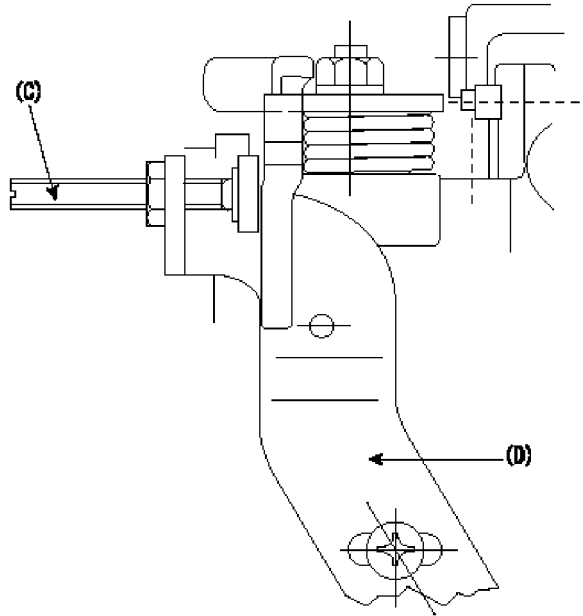

N1=750r/min
 V1=2.49+-0.03V
 Q1=8.7+-1cm³/1,000st
 Vi=10V

Adjusting method [applied voltage Vi, dummy bolt (C)]
 1. Hold the dummy bolt (C) against the control lever at position N = N1, Q = Q1. Fix using the lock nut.
 2. When adjusting the potentiometer, position the control lever against the dummy bolt (C) and adjust the potentiometer so that the output voltage is V1 (V).
 3. Remove the dummy bolt (C) after the completion of adjustment.
 Confirm that the potentiometer output voltage is within the above mentioned standards between the control lever's adjusting point and the idling position.
 N: Pump speed
 V: Output voltage
 Q: Injection quantity
 P: Boost pressure
 A: Adjusting point
 B: Checking point
 Q2: Idle
 Q3: Full speed
 (C): Dummy bolt
 (D): Bracket for mounting the dummy bolt

2.10.2 Additional device 2

Name	MICROSWITCH ADJUSTMENT
------	------------------------

N1=1000r/min
 Q1=29.1+-3.5cm³/1,000st
 V1=3.89+-0.05V
 T=2~2.9Nm{0.2~0.3kgfm}
 Vi=10V

(N)	(Q)	(A)	(V)
N1	Q1	(D)	V1
P [P1, P2]			Vi

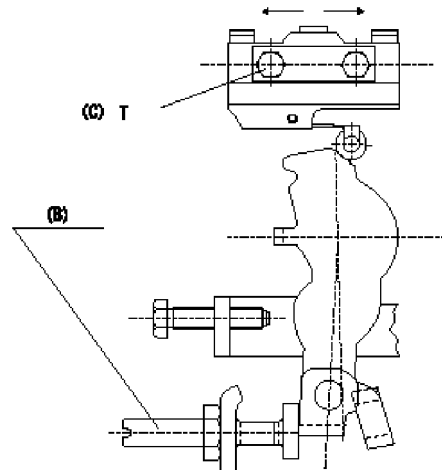

V1=3.89+-0.05V
 Vi=10V

1. Fix the dummy bolt B so that the potentiometer output voltage V1.
 2. Move the microswitch in the direction of the arrow and fix it where it turns OFF.
 3. Loosen dummy bolt B. Confirm that the potentiometer output voltage (V) is V1 where the microswitch turns from ON to OFF.
- After completing adjustment, remove the dummy bolt.
- (N): Speed of the pump
 (Q) Injection quantity
 (A) Microswitch operating direction
 (V) Output voltage
 (D) ON to OFF
 (P) Boost pressure
 (C) Microswitch fixing bolt
 Vi: Applied voltage

2.10.3 Additional device 3

Name	V-FICD ADJUSTMENT
------	-------------------

S1=1+1mm
 P1=-53.3kPa
 P2=-400mmHg

- Adjustment of the V-FICD
1. Adjust the actuator rod to obtain S1.
 2. Apply negative pressure P1 kPa {P2 mmHg} to the actuator and confirm that it moves through its full stroke.
- (A) Control lever (Idling position)

2.10.4 Additional device 4

Name STARTING I/Q ADJUSTMENT

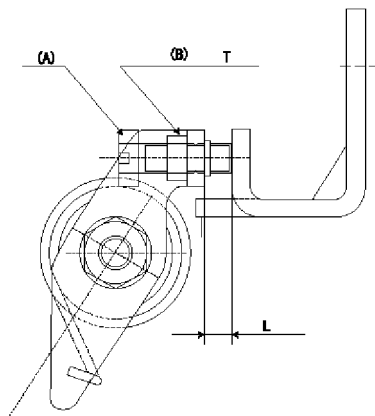
L=3~6mm
T=3.4~4.9N-m(0.35~0.5kgf-m)

Starting injection quantity adjustment
Adjust the adjusting bolt A so that the starting injection quantity adjustment is within the standards.
Fix using nut (B).

3 Assembly dimension

CAT	Designation	Unit	Set value	min.	max.	Actual values	OT
S	K dimension	mm	2.8	2.7	2.9		
S	KF dimension	mm	5.5	5.4	5.6		
S	MS dimension	mm	1	0.9	1.1		
S	BCS stroke	mm	3.9	3.8	4		
S	Pre-stroke	mm	0.43	-0.04	0.9		
S	Control lever angle alpha	deg.	24	20	28		
S	Control lever angle beta	deg.	48	43	53		